

CATENE PER APPLICAZIONI SPECIALI - TRASPORTATORI CON CATENE STRISCANTI

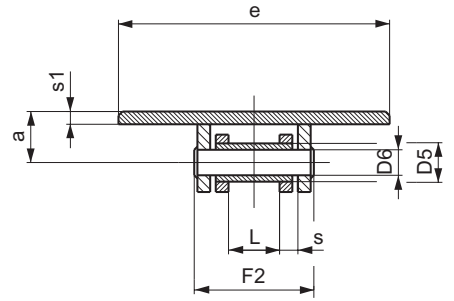

A PERNI PIENI

Catena N.	P mm	L mm	D5 mm	D6 mm	H mm	S mm	F2 mm	a mm	c mm	e mm	s mm	Carico di rottura N	Peso cat. kg/m
TB85	20	16	12	8	18,5	3	36	15,5	36	85	4	20.000	4,7

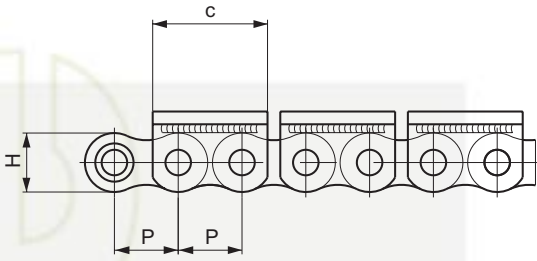
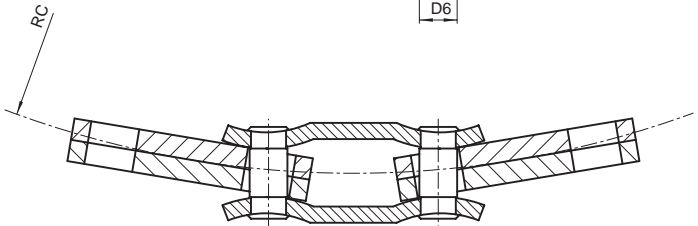
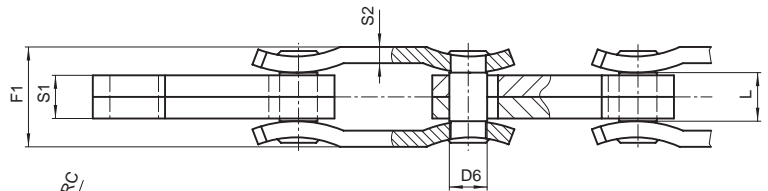
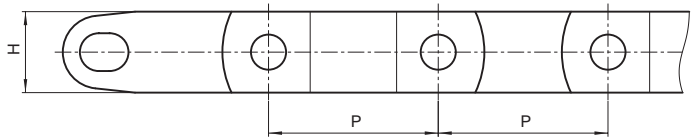

A PERNI PIENI

Catena N.	P mm	L mm	D6 mm	H mm	S1 mm	S2 mm	F1 mm	** RC mm	Carico di rottura N	Peso cat. kg/m
6285	62,85	18	14	30	16	6	38	400	130.000	5,1

** RC raggio minimo di curvatura

