

CATENE PER APPLICAZIONI SPECIALI - TABACCO

TUNNEL
ESSICCAZIONE

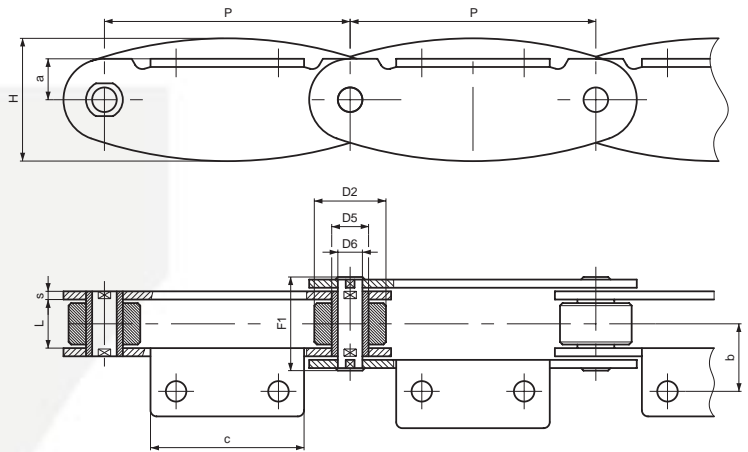

Catena N.	P mm	L mm	D2 mm	D6 mm	H mm	S mm	F1 mm	a mm	b mm	c mm	Carico di rottura N
W3571	120	22	35	12	60	4	43	20	33	75	90.000

TUNNEL
ESSICCAZIONE

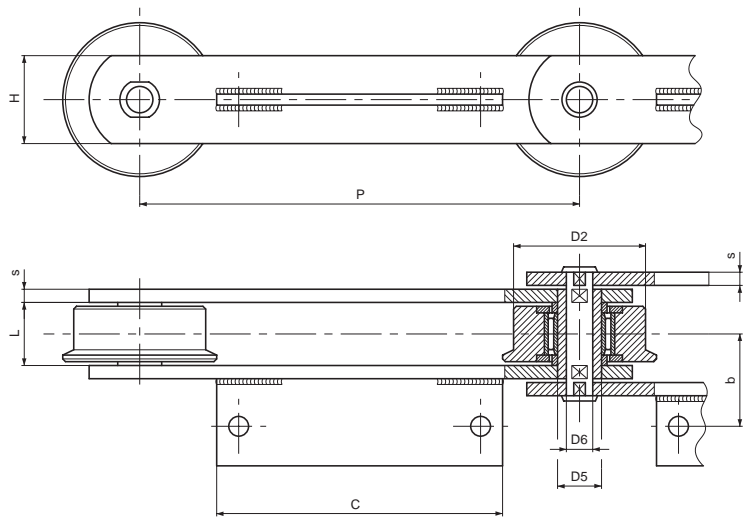

Catena N.	P mm	L mm	D2 mm	D6 mm	H mm	S mm	F1 mm	a mm	b mm	c mm	Carico di rottura N
W3616	200	28	60/70	12	40	5	55	2,5	42	130	60.000
W4088A	200	28	50/60	14	40	5	55	-2,5	40	110	130.000
W3840R**	200	37	60/70	20	40	5	64	2,5	46,5	130	150.000
W4919SS*	200	37	60/70	15	40	5	64	2,5	46,5	130	90.000
W4664	200	38	67/82	15	45	6	69	-2,5	47	110	180.000

* catena in acciaio inox
** senza astuccio a rullini



CATENE PER APPLICAZIONI SPECIALI - TABACCO

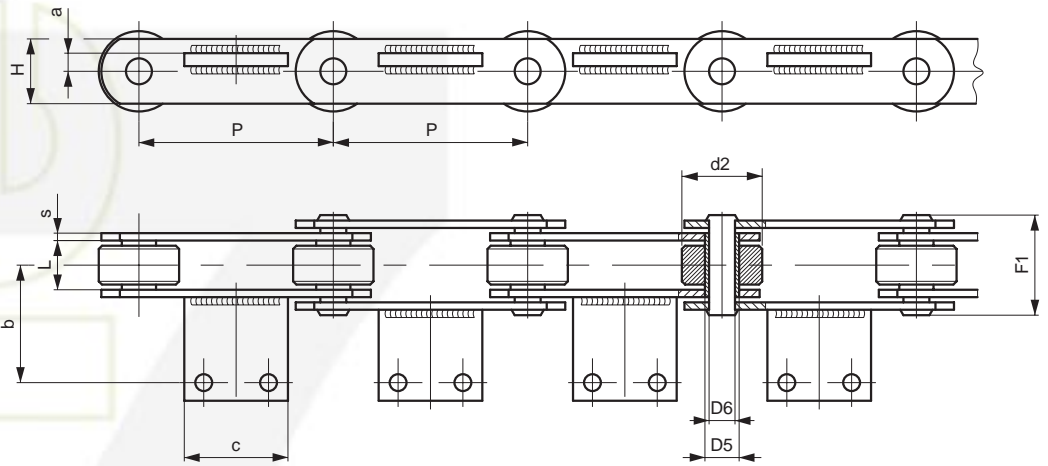

TUNNEL
ESSICCAZIONE

Catena N.	P mm	L mm	D2 mm	D6 mm	H mm	S mm	F1 mm	a mm	b mm	c mm	 Carico di rottura N	Note
W3977	75	15	31	10	25	4	36	7	33	40	45.000	
W1383	100	15	55	12	30	4	36	23	40	50	70.000	
W4010	100	26,5	50	12,6	35	5	54	6	41,5	55	100.000	
W3596R	100	26,5	50	12	35	5	54	-14	49,5	35	100.000	
W3458R	100	28	50	14,4	35	5	54,5	14	49,5	35	130.000	
W2988CR	200	26,5	60	16	40	5	54	2,5	43,5	130	150.000	
W2520	200	28	65	18	50	6	59	13	53	60	160.000	
W4088	200	28	50/60	12	40	5	59	-2,5	40	110	100.000	Rullo flangiato
W3808	200	37	70	18	50	7	72	3	62	115	260.000	
W3840R	200	37	60/70	12,4	40	5	63,5	2,5	46,5	130	110.000	Rullo flangiato
W3782	200	38,5	100/112	30	80	10/12	91	3	73	95	850.000	Rullo flangiato
W3790	200	38,5	100/112	36	90	12	97	-3,5	73	95	1.600.000	Rullo flangiato

